

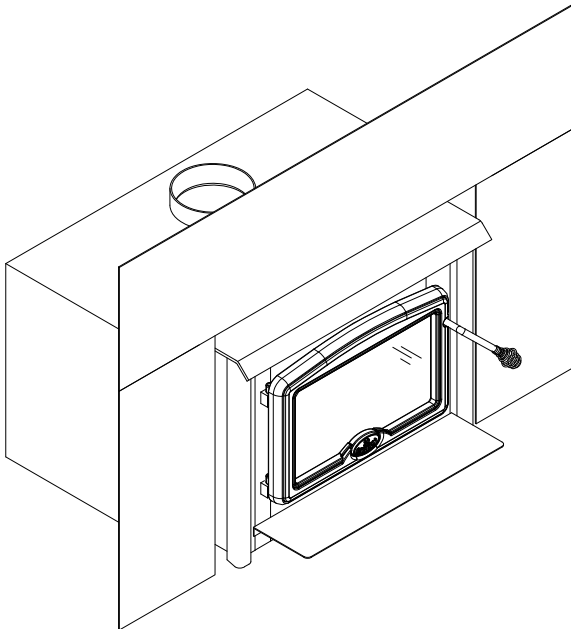

Beyond fire...

OWNER'S MANUAL

1600 MODEL INSERT



US ENVIRONMENTAL PROTECTION
AGENCY PHASE II CERTIFIED WOOD
INSERT

OREGON DEPARTEMENT
ENVIRONMENTAL QUALITY

Verified and tested following
ULC S628, UL 907, UL 1482 Standards by:

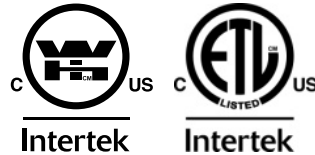

Manufactured by : **STOVE BUILDER INTERNATIONAL INC.**
250, rue de Copenhague, Saint-Augustin-de-Desmaures (Quebec) G3A 2H3
Tel.: 418 878-3040
Fax: 418 878-3001
www.osburn-mfg.com



This manual is available for free download on the manufacturer's web site. It is a copyrighted document. Re-sale is strictly prohibited. The manufacturer may update this manual from time to time and cannot be responsible for problems, injuries, or damages arising out of the use of information contained in any manual obtained from unauthorized sources.

READ AND KEEP THIS MANUAL FOR REFERENCE

TABLE OF CONTENTS

TECHNICAL SPECIFICATIONS	4
INSTALLATION	5
DOOR OVERLAY INSTALLATION	6
DOOR ADJUSTMENT	7
PRE-INSTALLATION REQUIREMENTS	7
MINIMUM MASONRY OPENING, CLEARANCES TO COMBUSTIBLES, AND FLOOR PROTECTOR.....	10
VENTING REQUIREMENTS	12
INSTALLATION INSTRUCTIONS	13
OPERATION	18
TESTING YOUR WOOD.....	19
THE FIRST FIRES	19
IGNITION.....	19
HEATING.....	20
RELOADING.....	20
CREOSOTE FORMATION AND NEED FOR REMOVAL.....	21
ASH DISPOSAL.....	21
MAINTENANCE	22
GLASS	22
GASKETING	22
PAINT	22
BAFFLE INSTALLATION	23
SECONDARY AIR TUBE REPLACEMENT	24
OSBURN LIMITED LIFETIME WARRANTY.....	25

REGISTER YOUR WARRANTY ONLINE

To receive full warranty coverage, you will need to show evidence of the date you purchased your insert.

Keep your sales invoice. We also recommend that you register your warranty online at

<http://www.osburn-mfg.com/warranty-registration.aspx>

Registering your warranty online will help us track rapidly the information we need on your insert.

INTRODUCTION

SBI INC., one of the most important wood stove and fireplace manufacturers in Canada, congratulates you on your purchase and wishes to help you get maximum satisfaction from your wood insert. In the pages that follow, we will give you advice on wood heating and controlled combustion as well as technical specifications regarding installation, operation and maintenance of the model you have chosen.

The instructions pertaining to the installation of your wood insert comply with ULC-S628 and UL-1482 standards.

Read this entire manual before you install and use your new insert. If this insert is not properly installed, a house fire may result. To reduce the risk of fire, follow the installation instructions. Failure to follow instructions may result in property damage, bodily injury, or even death.

Consult your municipal building department or fire officials about restrictions and installations requirements in your area and the need to obtain a permit.

Keep this instructions manual for future references.

CAUTIONS:

- HOT WHILE IN OPERATION. KEEP CHILDREN, CLOTHING AND FURNITURE AWAY. CONTACT MAY CAUSE SKIN BURNS.
- DO NOT USE CHEMICALS OR FLUIDS TO IGNITE THE FIRE.
- DO NOT LEAVE THE INSERT UNATTENDED WHEN THE DOOR IS SLIGHTLY OPENED.
- DO NOT BURN WASTES, FLAMMABLE FLUID SUCH AS GASOLINE, NAPHTHA OR MOTOR OIL.
- DO NOT CONNECT TO ANY AIR DISTRIBUTION DUCT OR SYSTEM.
- ALWAYS CLOSE THE DOOR AFTER THE IGNITION.

TECHNICAL SPECIFICATIONS

Combustible:	Wood
Recommended surface:	Up to 1800 square feet
Heating Capacity* :	E.P.A : 42,600 BTU/h Seasoned cordwood: 65,000 BTU/h
Optimum efficiency:	80%
Average emissions, EPA:	4.4 g/h
Color :	Metallic Black
Flue Pipe Diameter :	6" (152 mm)
Type de cheminée :	Maximum: 2100°F (1150 °C) Continuous: : 1200°F (650 °C)
Minimum Vertical Flue Height :	12' (3,66 m)
Maximum Log Length :	17 1/2" (445 mm)
Dimensions	
Overall:	W x D x H 24 1/8 x 22 x 21 1/2" (613 x 559 x 546 mm)
Combustion Chamber :	W x D
Width x Depth :	17 3/4 x 10 " (451 x 254 mm)
Volume :	1.85 ft ³ (0,052 m ³)
Door Opening:	W x H 8 3/8 x 15 3/4" (213 x 400 mm)
Weight:	360 lbs (164 Kg)

**Why is the BTU indicated on the EPA label smaller than the one advertised?*

You will notice a difference between the BTU output as indicated on the unit's white EPA label affixed to the glass and the BTU as advertised on our web site and/or product literature. The maximum BTU output we advertise for this unit is what will be obtained with a full load of seasoned cordwood inserted inside the firebox. The EPA output, on the other hand, is what has been obtained during emissions testing. The EPA test procedure requires that a special type of wood be used and positioned inside the firebox in a manner that does not represent the way the firebox volume would normally be utilized using seasoned cordwood. The EPA test load is typically much smaller. Hence, the BTU as per the EPA label is reduced. The BTU output that should be considered by a normal user is the one we advertise for seasoned cordwood.

INSTALLATION

SAFETY NOTICE

- IF THIS INSERT IS NOT PROPERLY INSTALLED, A HOUSE FIRE MAY RESULT. TO REDUCE THE RISK OF FIRE, FOLLOW THE INSTALLATION INSTRUCTIONS. FAILURE TO FOLLOW INSTRUCTIONS MAY RESULT IN PROPERTY DAMAGE, BODILY INJURY, OR EVEN DEATH.
- CONSULT YOUR MUNICIPAL BUILDING DEPARTMENT OR FIRE OFFICIALS ABOUT RESTRICTIONS AND INSTALLATIONS REQUIREMENTS IN YOUR AREA.
- USE SMOKE DETECTORS IN THE ROOM WHERE YOUR INSERT IS INSTALLED.
- KEEP FURNITURE AND DRAPES WELL AWAY FROM THE INSERT.
- NEVER USE GASOLINE, GASOLINE-TYPE LANTERN FUEL, KEROSENE, CHARCOAL LIGHTER FLUID, OR SIMILAR LIQUIDS TO START OR "FRESHEN UP" A FIRE. KEEP ALL SUCH LIQUIDS WELL AWAY FROM THE INSERT.
- IN THE EVENT OF A CHIMNEY FIRE, PUSH THE AIR CONTROL FULL CLOSED TO DEPRIVE THE FIRE OF OXYGEN. CALL THE FIRE DEPARTMENT.
- DO NOT CONNECT TO ANY AIR DISTRIBUTION DUCT OR SYSTEM.
- A SOURCE OF FRESH AIR INTO THE ROOM OR SPACE HEATED SHALL BE PROVIDED WHEN REQUIRED.
- A WOOD INSERT MUST NEVER BE INSTALLED IN A HALLWAY OR NEAR A STAIRCASE, SINCE IT MAY BLOCK THE WAY IN CASE OF FIRE OR FALL TO RESPECT REQUIRED CLEARANCES.
- DO NOT INSTALL IN A SLEEPING ROOM.

DOOR OVERLAY INSTALLATION

In order to complete the assembly of your Osburn 1600 wood insert, you need to install the door overlay. See figure 1 below for installation instructions :

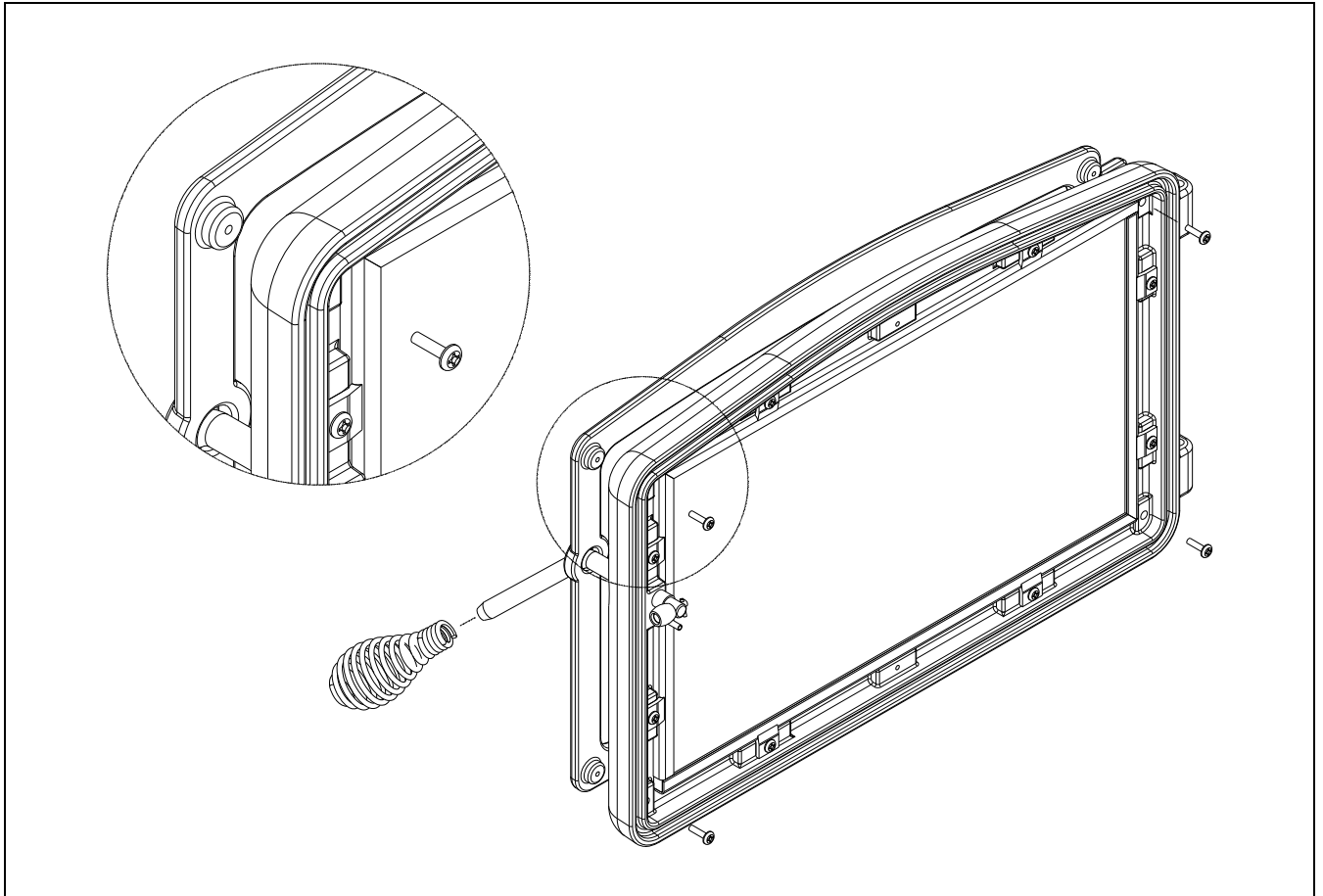

- 1- Position the overlay on the door frame and fix it in place from behind using the 4 screws.**

Note: It is not necessary to remove the glass or any other component to install the overlay.

Figure 1 : Door overlay installation

DOOR ADJUSTMENT

In order for your insert to operate properly, the door should be adjusted periodically to provide an air tight fit. To adjust:

- Remove the lock pin (spring pin) by pulling and turning it using pliers ("wise grip")
- Turn the handle counter clock wise one turn to increase pressure
- Re-install the lock pin (spring pin) with a small hammer

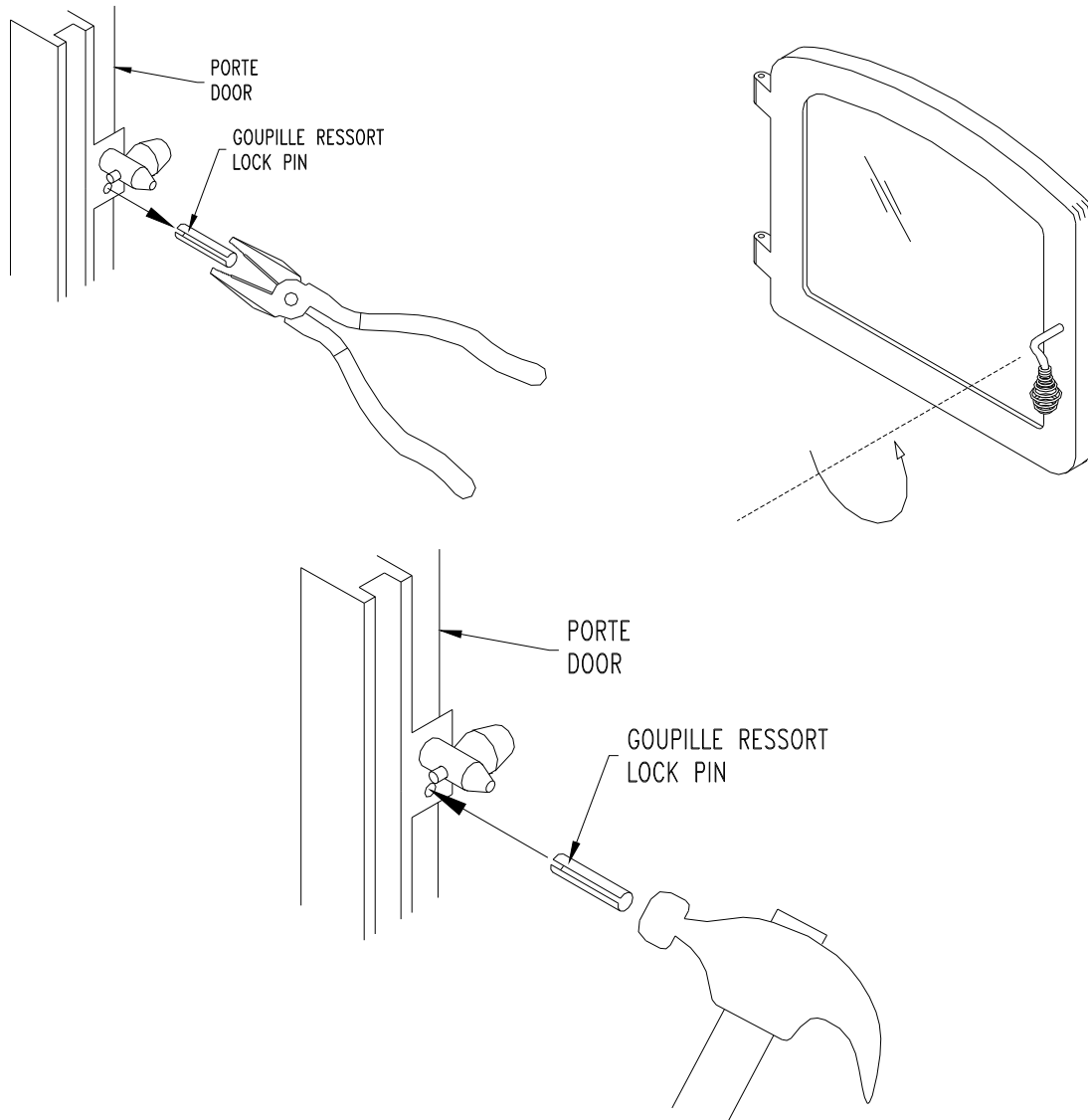

Figure 2: Door Adjustment

PRE-INSTALLATION REQUIREMENTS

MASONRY & ZERO CLEARANCE REQUIREMENTS

The masonry fireplace must meet the minimum code requirements, or NFPA 21,1 or the equivalent for a safe installation. Contact your local Building Inspector for requirements in your area. An inspection of the fireplace should include the following:

1. **CONDITION OF THE FIREPLACE AND CHIMNEY:** Examine the masonry fireplace and chimney prior to installation, to determine that they are free from cracks, loose mortar, creosote deposits, blockage, or other signs of deterioration. If evidence of deterioration is noted, the fireplace or chimney should be upgraded prior to installation.
2. **INSTALLATION INTO AN EXISTING FACTORY-BUILT ZERO-CLEARANCE FIREPLACE:** It is possible to install a wood insert into an existing factory-built zero-clearance fireplace. However, there currently exists no UL or ULC standard specific to that type of installation. The first thing that must be verified is that the factory-built zero clearance fireplace is listed (it must be certified by a competent certification body such as Omni or Warnock Hersey). It must be suitable for use with solid fuel and nothing in the owner's manual must specifically prohibit the installation of a fireplace insert. When in doubt, check with the fireplace manufacturer. The installation of the zero-clearance fireplace **MUST** be thoroughly inspected by a professional in order to ensure that it still meets the manufacturer's specs and code conformity. The chimney must be of at least 1" (25 mm) larger in diameter to accommodate a required continuous stainless steel liner running from the flue collar to the top of the chimney termination.

Never remove parts that serve to insulate the zero-clearance fireplace from combustible material. Only readily detachable parts that are easily replaced, such as damper parts, screens, and doors, are to be removed from the fireplace. These parts must be stored nearby and available for retrofit if the insert is ever removed. Removal of any parts which render the fireplace unfit for use with solid fuel requires the fireplace to be permanently labelled by the installer as being no longer suitable for solid fuel until the removed parts are replaced and the fireplace is restored to its original certified condition. Furthermore, any air vents, grilles, or louvers that serve to create an air circulation pattern around and outside the zero-clearance fireplace shall never be removed.

3. **HEARTH EXTENSION:** Verify that there is a non-combustible hearth extending at least 16" in front of the fireplace (18" for Canada, or 457 mm) and at least 8" (203mm) to the side of the fireplace. Fireplaces without this hearth extension will not meet the minimum requirements, and will require additional protection.

4. CHIMNEY CAPS: Mesh type chimney caps must have provision for regular cleaning, or the mesh should be removed to eliminate the potential of plugging.
5. LINER: The chimney must have an acceptable masonry liner suitable for solid fuel, otherwise a continuous stainless steel liner must be installed.
6. ADJACENT COMBUSTIBLES: The fireplace should be inspected to make sure that there is adequate clearance to combustibles, both exposed combustibles to the top, side, and front as well as concealed combustibles, in the chimney and mantle area. Your local inspector should have information on whether older fireplaces are of adequate construction.
7. OPENING SIZE: Refer to "Suitable Fireplace Dimensions" for suitable size fireplace openings.
8. The flue pipe must not go through roof trussing, an attic, a wardrobe, a floor, a combustible partition, or similar spaces.
9. A flue pipe crossing a combustible wall must have a minimum clearance of 18".
10. To reduce flue pipe clearances from combustible materials, contact your local safety department.

MINIMUM MASONRY OPENING, CLEARANCES TO COMBUSTIBLES, AND FLOOR PROTECTOR

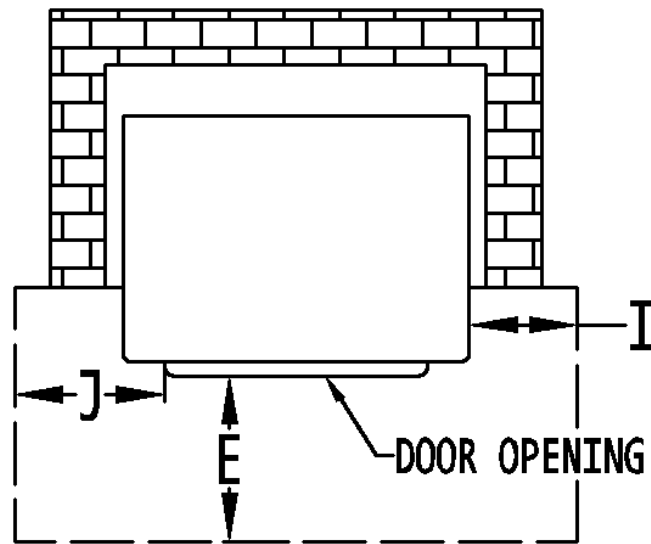
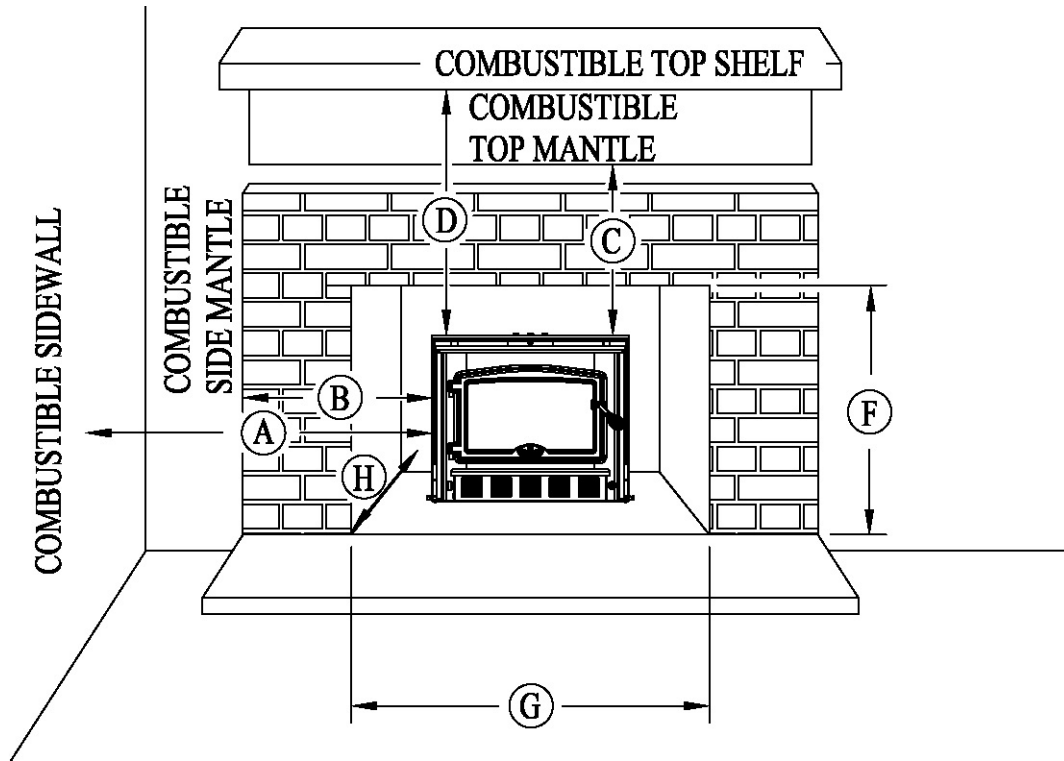

	MINIMUM MASONRY OPENING	MAXIMUM STANDARD FACEPLATE	MAXIMUM LARGE FACEPLATE
F	21.75" (553 mm)	29" (737 mm)	32" (813 mm)
G	26" (660 mm)	44" (1118 mm)	50" (1270 mm)
H	14.5" (368 mm)		

	CLEARANCES
A	16" (406 mm)
B	10" (254 mm)
C	16" (406 mm)
D	22" (559 mm)

	FLOOR PROTECTOR	
	CANADA	USA
E	18" (457 mm) – Note1	16" (406 mm) – Note 1
I	8" (203 mm)	N/A (Canada only)
J	N/A (USA only)	8" (203 mm)

Note 1: From door opening. The depth of a non-combustible shelf in from of the insert is included in the calculation of the floor protector's dimensions.

IMPORTANT: The masonry hearth should be at least 4 inches (102mm) higher than the combustible floor in front of it. If the hearth elevation is lower than 4 inches, the non-combustible floor protector in front of the insert should have an R value equal or greater than 1.00.

Sidewall (A)	16" (405mm)	From Insert Body
Side facing (B)	10" (255 mm)	
Top Facing Height(C)	35.5" (902 mm)	From Hearth Expansion
Mantle (D)	42" (1070 mm)	

VENTING REQUIREMENTS

The flue is a critical component to a satisfactory installation. Your insert will attain its best performance if installed with a flue that generates its own draft. The minimum venting requirement will be the installation of a flue connector from the insert into the first tile of the chimney (see Figure 2.3). If you are using a masonry chimney, it is important that it be built in compliance with the specifications of the National Building Code or other applicable standard having jurisdiction. It must be lined with fire clay bricks, metal or clay tiles sealed together with fire cement (round flues are the most efficient). Ideally, the interior diameter of the masonry chimney should be identical to the insert smoke exhaust. You may also run a stainless steel liner inside the masonry chimney. A continuous 6" (152mm) stainless steel liner from the top of the chimney to the insert's smoke exhaust (see Figure 2.2) is the optimum system and will provide the best performance, as well as compensate for poor draft situations caused by large cross-sectional chimneys. The insert will not work without a positive seal in the chimney.

Chimneys constructed outside of the home, on an exterior wall, should be avoided if possible, especially in colder climates. Outside chimneys may not draw as well and may downdraft due to the difficulty in heating them up to operating temperature. Cooler chimneys will result in increased creosoting, less draft, and poorer performance. Draft is proportional to overall chimney height as well as to stack temperature. Draft can be increased by increasing chimney height, and by reducing heat loss from the chimney through an insulated liner.

Ensure that all joints in the flue systems are tightly sealed, since any leaks will result in reduced performance as well as a possible safety hazard. Using a fire screen at the extremity of the chimney requires regular inspection in order to insure that it is not obstructed thus blocking the draught, and it should be cleaned when necessary.

Do not connect this unit to a chimney flue serving another appliance.

This heating unit must serve as a supplementary heat source. An alternate heat source should be available in the home if needed. The manufacturer cannot be responsible for additional heating costs associated with the use of an alternative heat source.

It is recommended that the user buys this product from a retailer who can provide installation and maintenance advices.

INSTALLATION INSTRUCTIONS

1. Inspect the fireplace according to the safety information and fireplace requirements and have it cleaned and/or upgraded as necessary.
2. If the installation of the unit renders the existing damper control inaccessible, it will be necessary to either secure the damper wide open or remove it entirely. An inaccessible damper which may fall shut later could cause smoke to enter the room. This would be a nuisance as well as a potential health hazard.
3. **POSITIVE CONNECTOR INSTALLATION:**

NOTE: A positive flue connector may provide acceptable performance, however, we recommend the use of a chimney liner to ensure satisfactory performance. Slip connectors for continuous liners should be installed similarly.

- A. Referring to the table and Figure 5, pick a location for the positive connector plate. It will be easiest to install the plate so that the hole for the flue is somewhere in between the extreme positions, and to use the adjustability of the faceplate to take up any inaccuracies in the fit. Alternatively, the plate itself can be moved up and back by using a 6" (152mm) extension directly on the flue.
- B. If you are securing the connector with a screw, the hole in the flue collar and the connector pipe should be drilled prior to final installation.
- C. Cut the plate to size and/or bend the edges over so that it will fit the cavity. The plate can then be secured to the throat of the fireplace using steel or masonry fasteners depending on the material. Locate the plate and drill through it into the backing material. Install the fasteners.
- D. Install the flat self-adhesive gasket around the inside of the 6" diameter (152mm) hole in the plate. Put the handle through the two holes in the throat connector (see Figure 4). Install the female end of the throat connector up through the hole in the plate so that it is held in position by friction, ready to be pulled down later.
- E. Positively seal any leaks between the plate and the brickwork. Any leaks will draw air into the fire, which will affect performance.

4. **POSITIONING THE UNIT:** The more extended the insert, the greater the heat transfer to the room. When installed as an extended insert, the front edge of the air jacket will be installed flush with the fireplace facing. Otherwise the unit can be moved back as much as 3.5" (89mm) or any position in between. The position chosen will depend on your own preference for most installations (where the lintel is less than 6" (152mm) and the depth is greater than 12.5" (318mm)). See the table and Figure 5.

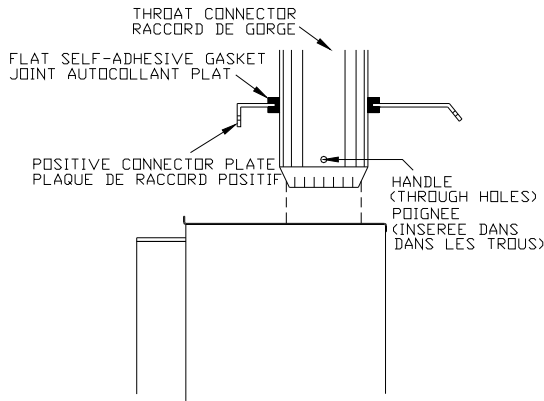

Figure 4

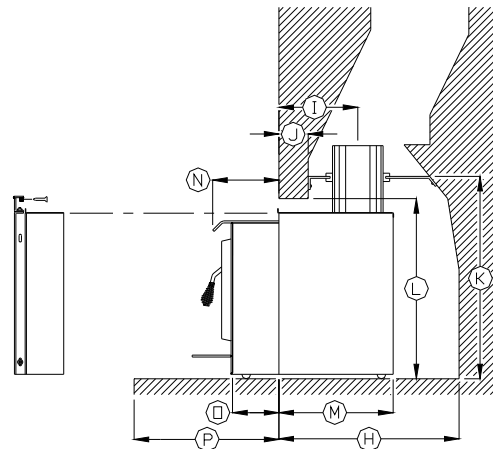

Figure 5

MAXIMUM EXTENDED	I	J	L	M	N	O	P	AIR JACKET
INCHES	8 1/2	6 1/2	23 - 28	14 1/2	8	6	24	Flush with facing
MILLIMETERS	216	165	584-711	368	203	152	610	
MINIMUM EXTENDED	I	J	L	M	N	O	P	AIR JACKET
INCHES	12	10	23 - 28	18	4 1/2	2 1/2	20 1/2	Back from facing 3 1/2"
MILLIMETERS	305	254	584-711	457	114	64	521	

5. If lag-bolts and anchors are to be used to secure the insert, the hole locations should be marked with the unit in place. Remove the unit and locate the anchors.

6. Remove the faceplate panels from their box and assemble according to these faceplate instructions:

A. Remove the slide from within the air jacket.

B. Place the faceplate face down on a flat, nonabrasive surface (see Figure 6) so that the sides are a bit towards the middle.

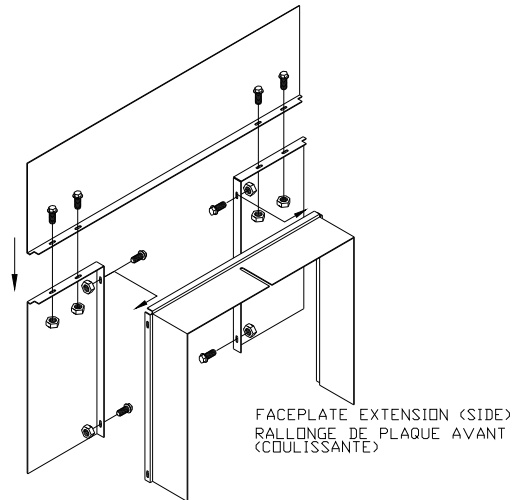

Figure 6

C. Place the slide onto the faceplate so that the bends of the faceplate pieces go inside of the slide.

D. Line up the holes by pushing the sides out and install (smooth heads inside) all the bolts loosely. Line up the edge of the faceplate top and side, tighten the two bolts joining them, and then tighten the side bolts. Tighten the bolts on the other side in the same manner (see Figure 7).

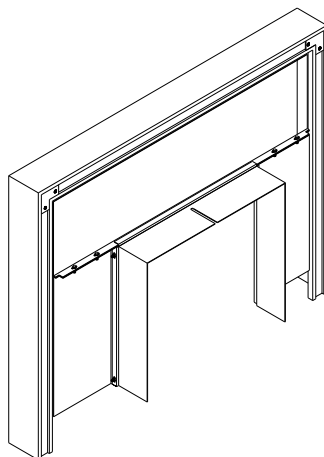

Figure 7

7. **INSTALLATION ON FACEPLATE:** Attach the mitred corners of trim together using the corner brackets. Slide the assembled trim over the edge of the faceplate. See Figures 8 and 9.

Attach the left and right sides to the top with corner brackets supplied. Slip the trim over the faceplate and snap the eight faceplate trim clips in place (see Figure 8).

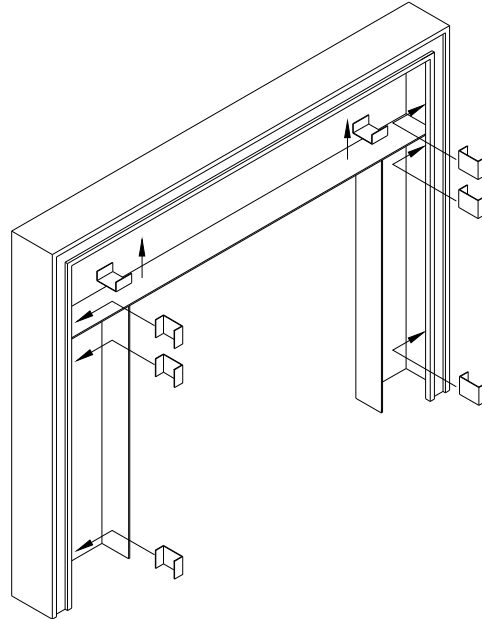

Figure 8

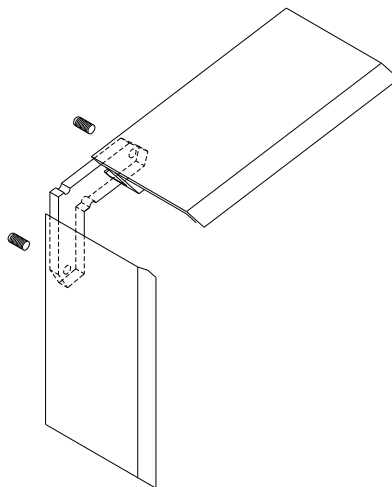

Figure 9

8. Lift the insert into the fireplace. Square the insert to the face of the fireplace by adjusting the levelling legs on the sides at the rear of the insert. Check that the throat connector is in line.

9. If there is space to push the connector down from above, do so. Reach in through the insert and pull the throat connector down into place. If you are securing the connector to the flue collar with the screw, do that now.

10. Push the air control (A) in, all the way. Slide the adjustable faceplate sleeve back into its original location until the faceplate fits tightly against the fireplace facing. See Figure 10. One 7/16" (11mm) open end wrench should be used to turn the nut (B), located above the cooktop in the center, up so that it securely fastens the adjustable faceplate sleeve to the top air jacket. Take the air control slider spring handle (C) from the firebox and turn it onto the 1/4" diameter (6mm) air control rod (A).

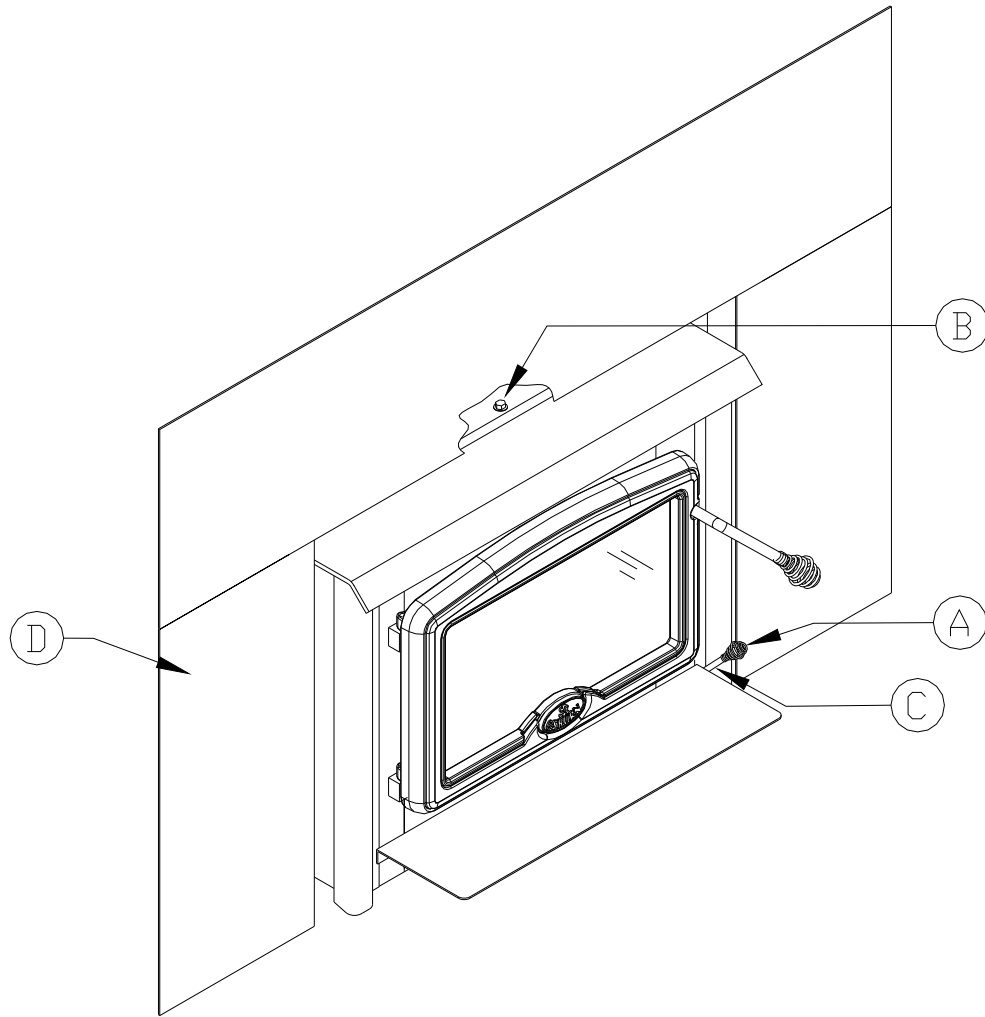

Figure 10

OPERATION

Your heating unit was designed to burn wood only; no other materials should be burnt. Wastes and other flammable materials should not be burnt in your wood insert. Any type of wood may be used in your insert, but specific varieties have better energy yields than others. Please consult the following table in order to make the best possible choice.

Average Energy Yield Of One Air Dried Cord Of Cut Wood

	Wood species	Energy yield (millions of BTU/cord)
High energy yield	Oak	29
	Sugar Maple	28
	Beech	26
	Yellow birch	25
	Ash	24
	Elm	23
Medium energy yield	Larch (Tamarack)	23
	Red Maple	23
	Douglas red fir	23
	Silver birch	22
	Alder	18
	Poplar	17
	Hemlock	17
Low energy yield	Spruce	17
	Pine	17
	Bass	16
	Fir	13

Data provided by Energy, Mines and Resources - Canada

IT IS EXTREMELY IMPORTANT THAT YOU USE DRY WOOD ONLY IN YOUR WOOD INSERT. The wood must have dried for 9 to 15 months, such that the humidity content (in weight) is reduced below 20% of the weight of the log. It is very important to keep in mind that even if the wood has been cut since one, two or even more years, it is not necessarily dry, if it has been stored in poor conditions; under extreme conditions, it may even rot instead of drying. The vast majority of the problems related to the operation of a wood insert are caused by the fact that the wood used was too damp or had dried in poor conditions. These problems can be:

- ignition problems
- creosote build-up causing chimney fires
- low energy yield
- blackened windows
- incomplete log combustion

Smaller pieces of wood will dry faster. All logs exceeding 6" in diameter should be split. The wood should not be stored directly on the ground. Air should circulate through the cord. A 24" to 48" air space should be left between each row of logs, which should be placed in the sunniest location possible. The upper layer of wood should be protected from the element but not the sides.

TESTING YOUR WOOD

When the insert is thoroughly warmed, place one piece of split wood (about five inches in diameter) parallel to the door on the bed of red embers. Keep the air control full open by pulling on it and close the door. If ignition of the piece is accomplished within 90 seconds from the time it was placed in the insert, your wood is correctly dried. If ignition takes longer, your wood is damp. If your wood hisses and water or vapour escapes at the ends of the piece, your wood is soaked or freshly cut. Do not use this wood in your insert. Large amounts of creosote could be deposited in your chimney, creating potential conditions for a chimney fire.

THE FIRST FIRES

The fresh paint on your insert needs to be cured to preserve its quality. Once the fuel charge is properly ignited, only burn small fires in your insert for the first four hours of operation. Never open the air control more than necessary to achieve a medium burn rate. Make sure that there's enough air circulation while curing the insert. The odours could be smelled during the 3 or 4 first fires. The light smoke created by the paint curing process is not toxic. Never start your insert outside. You will not be able to see if you are over heating.

IGNITION

After making sure that the insert air intake controls are fully open, place several crumpled sheets of paper in the centre of the combustion chamber. Place 8 to 10 pieces of small dry kindling wood over the paper in the form of a tent. You may also place a few pieces of heating wood, but choose the smaller ones. No chemical product should be used to light the fire. Before igniting the paper and kindling wood, it is recommended that you warm up the chimney. This is done in order to avoid back draft problems often due to negative pressure in the house. If such is the case, open a window slightly near the insert and twist together a few sheets of newspaper into a torch. Light up this paper torch and hold it as close as possible to the mouth of the pipe inside the combustion chamber to warm up the chimney. Once the updraft movement is initiated, you are ready to ignite the insert by lighting the paper and kindling wood inside the combustion chamber. We therefore advise you to leave the door slightly opened (1/4") for a 10 to 30 minutes period, **under supervision**, in order to allow for good combustion. After this time, you must close the door and progressively adjust the air control to obtain the desired temperature.

HEATING

Controlled combustion is the most efficient technique for wood heating because it enables you to select the type of combustion you want for each given situation. The wood will burn slowly if the wood insert air intake control is adjusted to reduce the oxygen supply in the combustion chamber to a minimum. On the other hand, wood will burn quickly if the air control is adjusted to admit a larger quantity of oxygen in the combustion chamber. The air intake control on your insert is very simple. If you move it completely to the right, it is fully open. If you move it completely to the left, it is fully close.

Your OSBURN insert burnt between .979 kg\h and 4.4 kg\h. of wood during EPA testing. Real operating conditions may give very different results than those obtained in the lab according to the species of wood used, its moisture content, the size and density of the pieces, the length of the chimney, altitude and outside temperature.

In order to achieve an optimum efficiency from your unit, we suggest that you operate it with the air control slightly open (approximately 10%). Make sure that you have a good fire going and an adequate ember bed before you completely close the air control. Closing the air control too soon will lower combustion efficiency and may cause the fire to die out. The addition of a blower (if not already included) is highly recommended to maximize your unit's efficiency.

WARNINGS

- NEVER OVERFIRE YOUR INSERT. IF ANY PART OF THE INSERT STARTS TO GLOW RED, OVER FIRING IS HAPPENING. READJUST THE AIR INTAKE CONTROL AT A LOWER SETTING.
- THE INSTALLATION OF A LOG CRADLE IS NOT RECOMMENDED IN YOUR OSBURN WOOD INSERT.
- NEVER PUT WOOD ABOVE THE FIREBRICK LINING OF THE FIREBOX.

RELOADING

Once you have obtained a good bed of embers, you should reload the unit. In order to do so, open the air controls to maximum a few seconds prior to opening the insert's door. Then proceed by opening the door very slowly; open it one or two inches for 5 to 10 seconds, before opening it completely to increase the draught and thus eliminate the smoke which is stagnant in a state of slow combustion in the insert. Then bring the red embers to the front of the insert and reload the unit.

For optimal operation of your wood insert, we recommend you to operate it with a wood load approximately equivalent to the height of fire bricks.

It is important to note that wood combustion consumes ambient oxygen in the room .In the case of negative pressure, it is a good idea to allow fresh air in the room, either by opening a window slightly or by installing a fresh air intake system on an outside wall.

CREOSOTE FORMATION AND NEED FOR REMOVAL

When wood is burned slowly, it produces tar and other organic vapours, which combine with expelled moisture to form creosote. The creosote vapours condense in the relatively cool chimney flue of a slow-burning fire. As a result, creosote residue accumulates on the flue lining. When ignited this creosote makes an extremely hot fire. When burning wood, the chimney connector and chimney should be inspected at least once every two months during the heating season to determine if a creosote build-up has occurred.

TO PREVENT CREOSOTE BUILD UP

- Always burn dry wood. This allows clean burns and higher chimney temperatures, therefore less creosote deposit.
- Leave the air control full open for about 10 min. every time you reload the insert to bring it back to proper operating temperatures. The secondary combustion can only take place if the firebox is hot enough.
- Always check for creosote deposit once every two months and have your chimney cleaned at least once a year.

ASH DISPOSAL

Ashes should be removed from the insert every few days or when ashes get to 2 to 3 inches deep. Always empty the insert when it is cold, such as in the morning.

Always dispose of ashes in a metal container with a tight fitting lid. Place this container on a non combustible floor or on the ground, well away from all combustible materials, pending final disposal. If the ashes are disposed of by burial in soil or otherwise locally dispersed, they should be retained in the close container until all cinders have thoroughly cooled.

CAUTIONS:

- ASHES COULD CONTAIN HOT EMBERS EVEN AFTER TWO DAYS WITHOUT OPERATING THE INSERT.
- THE ASH PAN CAN BECOME VERY HOT. WEAR GLOVES TO PREVENT INJURY.
- NEVER BURN THE INSERT WITH THE ASH TRAP OPEN. THIS WOULD RESULT IN OVER FIRING THE INSERT. DAMAGE TO THE INSERT AND EVEN HOUSE FIRE MAY RESULT.

MAINTENANCE

Your OSBURN insert is a high efficiency insert and therefore require little maintenance. It is important to perform a visual inspection of the insert every time it is emptied, in order to insure that no parts have been damaged, in which case repairs must be performed immediately.

GLASS

- Inspect the glass regularly in order to detect any cracks. If you spot one, turn the insert off immediately. Do not abuse the glass door by striking or slamming shut. Do not use the insert if the glass is broken.
- If the glass on your insert breaks, replace only with glazing supplied from the OSBURN dealer.
- To replace the glass, remove the screws retaining the gasket frame inside the door and lift. Replace the damaged piece with a new one. Perform the procedure backwards after replacing. When replacing the glass, you should change the glass gasket to make sure you keep it sealed.
- Never wash the glass with a product that may scratch. Use a specialized product, available in the stores where wood inserts are sold.
- The glass should be washed only when cold.

GASKETING

It is recommended that you change the door gasket (which makes your insert door air tight) once a year, in order to insure good control over the combustion, maximum efficiency and security. To change the door gasket, simply remove the damaged one. Carefully clean the available gasket groove, apply a high temperature silicone sold for this purpose, and install the new gasket. You may light up your insert again approximately 24 hours after having completed this operation.

WARNING:

- NEVER OPERATE THE INSERT WITHOUT A GASKET OR WITH A BROKEN ONE. DAMAGE TO THE INSERT OR EVEN HOUSE FIRE MAY RESULT

PAINT

Only clean your insert with a dry soft cloth that will not harm the paint finish. If the paint becomes scratched or damaged, it is possible to give your wood insert a brand new look, by repainting it with a 1200° F heat resistant paint. For this purpose, simply scrub the surface to be repainted with fine sand paper, clean it properly, and apply thin coats (2) of paint successively.

BAFFLE INSTALLATION

All firebrick and ceramic wool baffles must be properly in place for correct burning operation. Have any damaged firebricks replaced. Check the firebricks annually for damage and replace if they are broken or damaged. See figure 11 for the firebrick layout.

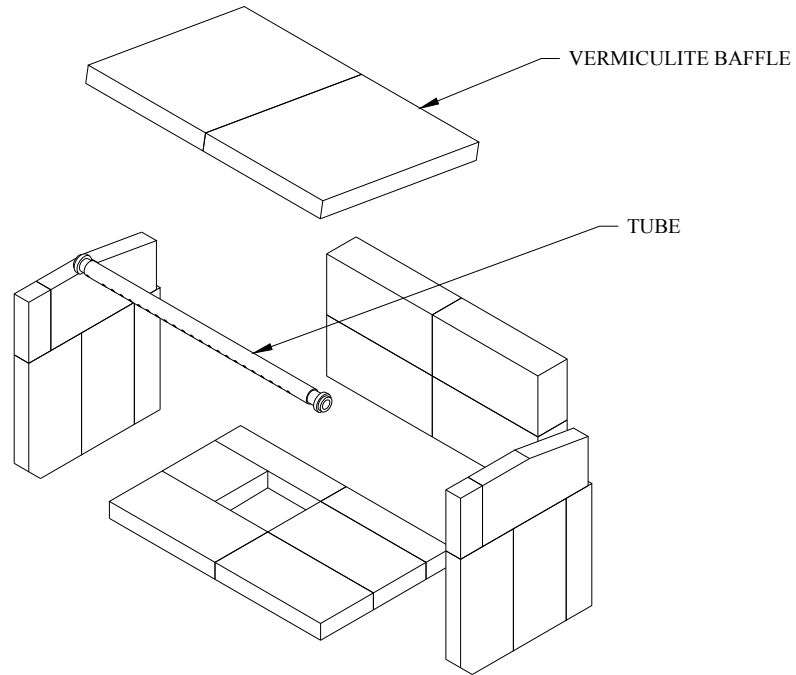

Figure 11 - Baffle installation

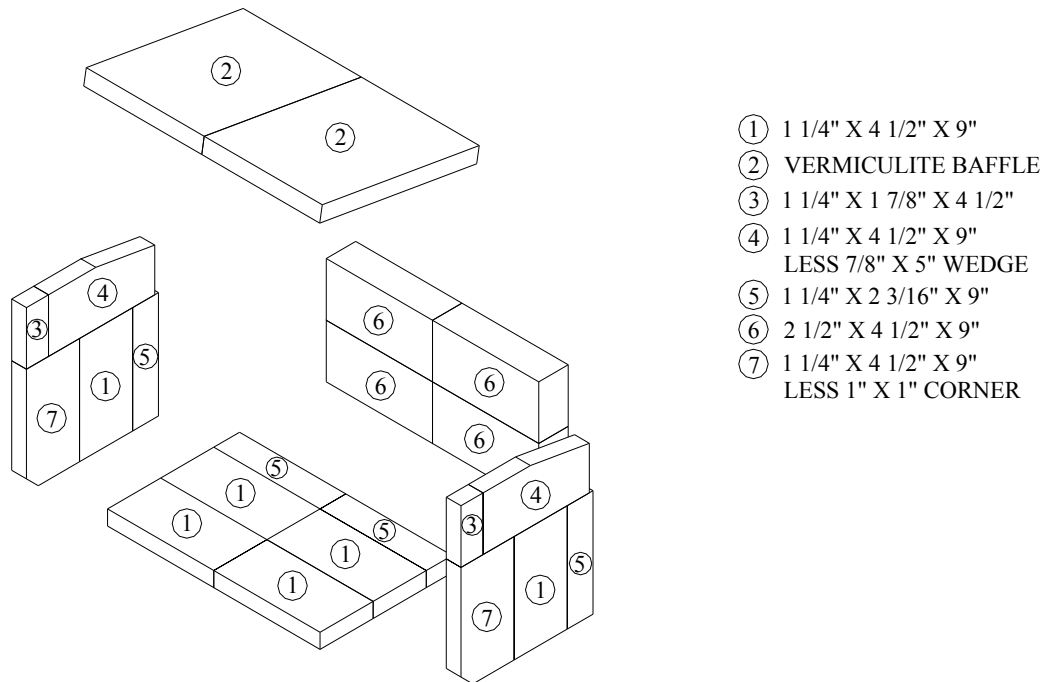
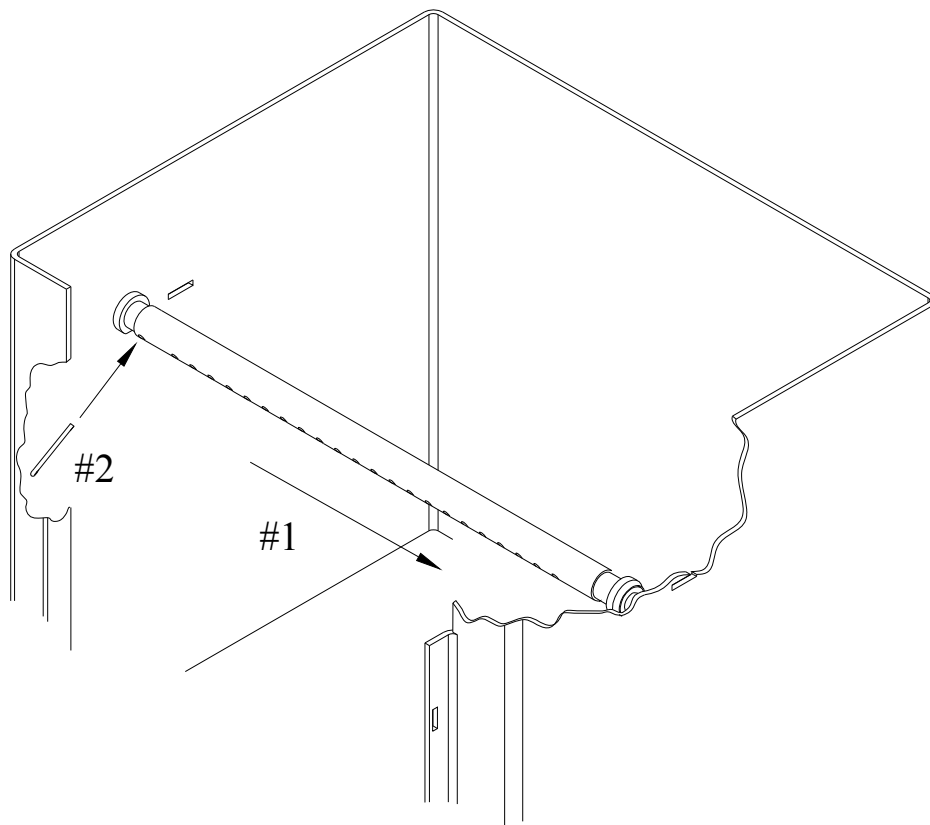

Figure 12 - Firebrick layout

SECONDARY AIR TUBE REPLACEMENT

1. Remove cotter pin at left end of tube.
2. Slide tube to right and lower tube end below left plenum.
3. Slide tube to left to remove.
4. Reassemble in reverse order using a new cotter pin. The cotter pin is a hammerlock style and locks into place by hitting the head sharply with a hammer.
5. Note that any tube can be replaced without disturbing the baffle.



The air tubes are identified for placement as follows:

Model	Type of tube
Osburn 1600 Insert	Front ► 22 holes of 1/4"

OSBURN LIMITED LIFETIME WARRANTY

The warranty of the manufacturer extends only to the original consumer purchaser and is not transferable. This warranty covers brand new products only, which have not been altered, modified nor repaired since shipment from factory. Proof of purchase (dated bill of sale), model name and serial number must be supplied when making any warranty claim to your OSBURN dealer.

This warranty applies to normal residential use only. Damages caused by misuse, abuse, improper installation, lack of maintenance, over firing, negligence, accident during transportation, power failures, downdrafts, or venting problems are not covered by this warranty.

This warranty does not cover any scratch, corrosion, warping, or discoloration caused by over firing, abrasives or chemical cleaners. Any defect or damage caused by the use of unauthorized parts or others than original parts void this warranty. An authorized qualified technician must perform the installation in accordance with the instructions supplied with this product and all local and national building codes. Any service call related to an improper installation is not covered by this warranty.

The manufacturer may require that defective products be returned or that digital pictures be provided to support the claim. Returned products are to be shipped prepaid to the manufacturer for investigation. If a product is found to be defective, the manufacturer will repair or replace such defect. Transportation fees to ship the product back to the purchaser will be paid by the manufacturer. Repair work covered by the warranty, executed at the purchaser's domicile by an authorized qualified technician requires the prior approval of the manufacturer. Labour cost and repair work to the account of the manufacturer are based on predetermined rate schedule and must not exceed the wholesale price of the replacement part. All parts and labour costs covered by this warranty are limited according to the table below.

The manufacturer at its discretion may decide to repair or replace any part or unit after inspection and investigation of the defect. The manufacturer may, at its discretion, fully discharge all obligations with respect to this warranty by refunding the wholesale price of any warranted but defective parts. The manufacturer shall in no event be responsible for any special, indirect, consequential damages of any nature, which are in excess of the original purchase price of the product. A one-time replacement limit applies to all parts benefiting from a lifetime coverage. This warranty applies to products purchased after March 1st, 2009.

DESCRIPTION	WARRANTY APPLICATION	
	PARTS	LABOUR
Combustion chamber (welds only), castings, convector air-mate, ceramic glass (thermal breakage only*), and secondary air tubes*.	Lifetime	5 years
Plating* (defective manufacture) – subject to limitations above.	Lifetime	n/a
Stainless steel firebox components, surrounds and heat shields, ash drawer, steel legs, pedestal, trims (aluminum extrusions), C-Cast baffle*, and vermiculite baffle*.	7 years	5 years
Carbon steel firebox components, glass retainers, and handle assembly.	5 years	3 years
Blowers, heat sensors, switches, rheostat, wiring, and other controls.	2 years	1 year
Paint (peeling), gaskets, insulation, firebrick, and ceramic fibre blankets.	1 year	n/a

*Pictures required

Shall your unit or a components be defective, contact immediately your **OSBURN** dealer. Prior to your call make sure you have the following information necessary to your warranty claim treatment:

- Your name, address and telephone number;
- Bill of sale and dealer's name;
- Serial number and model name as indicated on the nameplate fixed to the back of your unit;
- Nature of the defect and any relevant information.

Before shipping your unit or defective component to our plant, you must obtain from your OSBURN dealer an Authorization Number. Any merchandise shipped to our plant without authorization will be refused automatically and returned to sender.