



269 East Main Street Berne, IN 46711

Phone: (260) 589-8536 Web: www.hitzer.com

E-Mail: info@hitzer.com

OWNER'S MANUAL

INSTALLATION AND OPERATION

FOR HITZER MODEL 82

Save These Instructions

- Installation, Operating, and Maintenance Instructions Enclosed.
 - Thoroughly Read and Understand Instructions.
 - Installer Always Leave this Manual with Stove Owner.

Warning

- **READ THIS ENTIRE MANUAL BEFORE YOU INSTALL AND USE YOUR NEW ROOM HEATER. IF THIS ROOM HEATER IS NOT PROPERLY INSTALLED, A HOUSE FIRE MAY RESULT. TO REDUCE THE RISK OF FIRE, FOLLOW THE INSTALLATION AND OPERATING INSTRUCTIONS.**
- **FOLLOW THE INSTRUCTIONS WITHIN THIS MANUAL. IF INSTRUCTIONS ARE NOT FOLLOWED, A FIRE MAY RESULT CAUSING PROPERTY DAMAGE, PERSONAL INJURY, OR EVEN DEATH.**
- **HOT WHILE IN OPERATION. KEEP CHILDREN, CLOTHING AND FURNITURE AWAY. CONTACT MAY CAUSE SKIN BURNS.**
- **FOR USE OF SOLID FUEL, COAL ONLY. OTHER FUEL SOURCES CAN RESULT IN POISONOUS GAS EMISSION, STOVE DAMAGE, AND/OR FIRE.**
- **FOR BEST RESULTS USE NUT OR PEA SIZED ANTHRACITE COAL. RUN OF MINE, LUMP, AND EGG SIZE BITUMINOUS COAL MAY ALSO BE USED**
- **CARBON MONOXIDE AND SMOKE DETECTORS MUST BE PRESENT IN HOME AND WORKING PROPERLY AT ALL TIMES.**

I. Welcome to Hitzer Family

Hitzer Inc. welcomes you to a proud and unified team of Hitzer stove owners. Thank You for your recent purchase of a Hitzer Furnace. We can assure you that your Hitzer stove has the finest Swiss Amish Craftsmanship. Your Hitzer Stove is built with premier quality materials to ensure safety, durability, and performance. These are all top priorities in the Hitzer line of products.

We would like to personally thank you again and welcome you into our continually growing Hitzer Family. We wish you and your family an extended amount of warmth and comfort, provided by your new Hitzer Stove. Thanks for choosing Hitzer as “Our Stoves Make Warm Friends.”

Safety Notice

CAUTION: IF THIS HITZER STOVE IS NOT PROPERLY INSTALLED A HOUSE FIRE MAY RESULT. FOR YOUR SAFETY AND TO REDUCE THE RISK OF FIRE, FOLLOW THE INSTALLATION INSTRUCTIONS CAREFULLY. FAILURE TO FOLLOW THESE INSTRUCTIONS MAY RESULT IN PROPERTY DAMAGE, BODILY INJURY, OR EVEN DEATH. CONTACT YOUR LOCAL BUILDING INSPECTOR OR FIRE OFFICIALS ABOUT THE NEED FOR A PERMIT, RESTRICTIONS, OR INSTALLATION INSPECTION REQUIRED IN YOUR AREA. SAVE THESE INSTRUCTIONS FOR FUTURE REFERENCE.

UL Tested/Label: Follow the information and clearance charts located on each Hitzer Stove Model. These stoves have been tested to UL 1482, approved, and labeled on the rear of each stove.

It is strongly recommended to have this Hitzer Stove installed by an educated and certified installation professional. Please refer to a NFI (National Fireplace Institute) Certified Installer for your installation needs and questions. Locate an NFI professional at www.nficertified.org.



II. Flue Systems

Masonry Flue System: A good chimney is essential. A masonry chimney must be built with a low heat masonry material. It is important to make sure that the masonry chimney is code approved, structurally sound and on a solid foundation. The masonry chimney must have a liner installed within the chimney construction. An unlined chimney is not safe with solid fuel systems, and may result in a house fire. The liner may be constructed with a structurally sound clay liner or a stainless steel liner. If using an existing masonry chimney, be sure to have the chimney examined and cleaned by a chimney professional. The structural foundation of the chimney and liner is important. If existing clay liner is cracked or damaged, it is recommended to re-line the chimney with a stainless steel liner. Be sure the masonry chimney is compatible with the local building codes and requirements.

Factory Built System: A good chimney is essential. The factory built chimney must be a Class A High Temperature UL tested chimney UL 103 HT. It is required for this Class A chimney to be listed and labeled under the UL standards. If using an existing factory built Class A chimney it must be inspected and cleaned by a certified chimney professional, before use. With Factory Built Chimneys the chimney manufacturer's clearances and distance requirements must be followed. It is also important to abide by the rules and regulations of local jurisdictions upon chimney installation. Like masonry chimneys, you can only have one appliance per chimney, and it is not permissible to connect the Hitzer Stove to a chimney that is servicing another appliance.

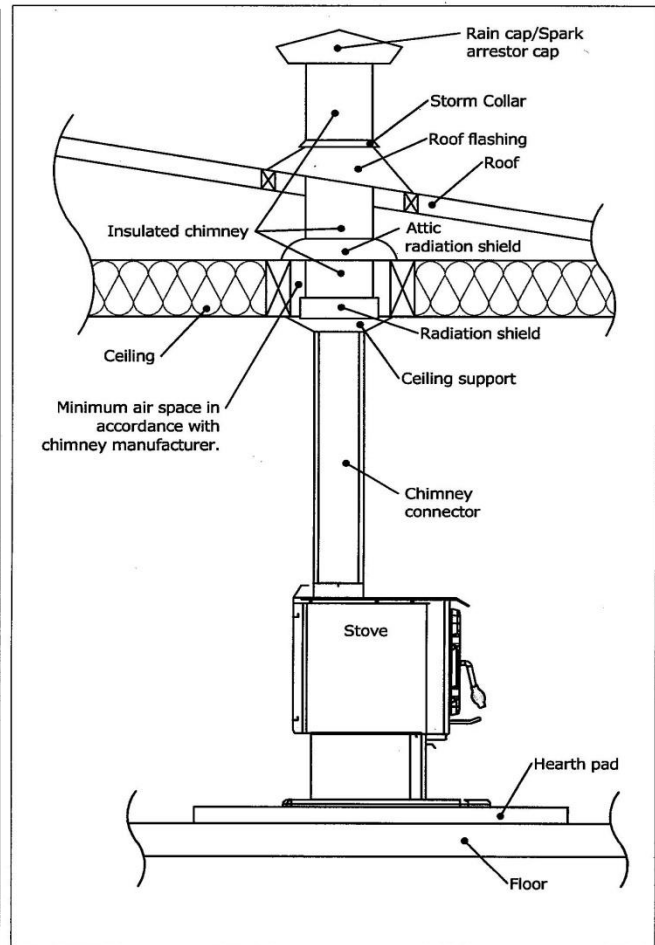
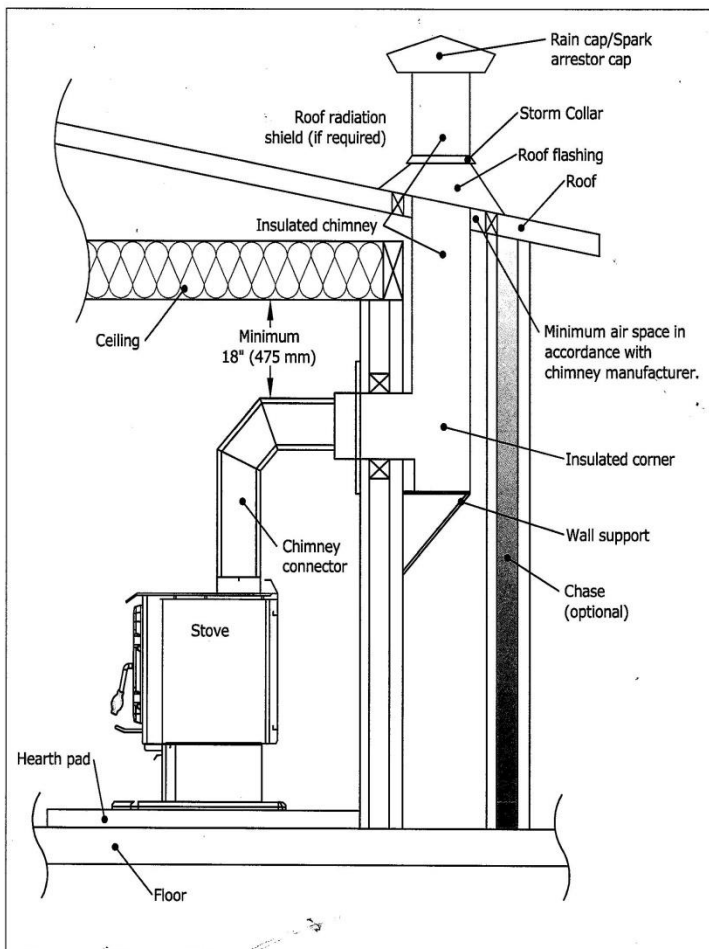

THE DIAGRAMS ARE FOR INFORMATIONAL PURPOSES ONLY. FOLLOW CHIMNEY MANUFACTURER'S INSTALLATION INSTRUCTIONS.

WARNING: BE SURE TO FOLLOW ALL CHIMNEY MANUFACTURER’S INSTRUCTIONS. FAILURE TO FOLLOW INSTRUCTIONS CAN RESULT IN FIRE, INJURY, AND EVEN DEATH.

CAUTION: DO NOT CONNECT THIS UNIT TO A CHIMNEY SERVING ANOTHER APPLIANCE.

Flue Requirements: It is required to have your chimney inspected and cleaned by a certified chimney professional if needed before your Hitzer Stove installation. The flue and connector should be inspected at least monthly during the heating season. If material has accumulated, it should be removed immediately to reduce the risk of a chimney fire. If a chimney fire does occur the fire department should be called immediately and the draft controls should be closed on the stove. It is also required to have a chimney that is built according to the chimney manufacturer’s specifications and it must meet local building codes.

Flue Size: The proper flue size is very important. The proper flue size is essential in order to have the correct amount of draft required to operate the Hitzer Stove. The diameter of the flue size including chimney liner should never be less than the diameter of the flue exhaust collar on the Hitzer model 82. The flue size for the model 82 should be a minimum of 7 inches in diameter.

Flue Size (Continued): The flue size also has a maximum size of inches in order to sustain the desired draft. For an **interior chimney** the flue and chimney liner size cannot be larger than 3 times the square inches of the flue exhaust collar on the Hitzer stove. For an **exterior chimney** that has at least one side exposed to the exterior of the house the flue and chimney liner cannot be more than 2 times the square inches of the flue exhaust collar of the Hitzer Stove. Also keep in mind the warmer the chimney is the better the draft.

Model	Flue Size (Sq. Inch)	Minimum (Sq. inch)	Maximum (Sq. Inch)	Int/Ext
82	7" 38.5 sq. in.	7" 38.5 sq. in.	115.5 sq. in.	interior
82	7" 38.5 sq. in.	7" 38.5 sq. in.	77 sq. in.	exterior

Chimney Height Requirements: The minimum height of a chimney system for the Hitzer Stove is 15 feet. The chimney must exceed the roof of a house a minimum of 3 feet at any point of exit. In pitched roof installation the chimney must be 2 feet higher than anything within a 10 foot radius of the chimney. It is important to have a chimney draft of -.03 to -.06 (kPa) It is required to abide by the manufacturer’s instructions on class A chimney’s as well as local building codes.

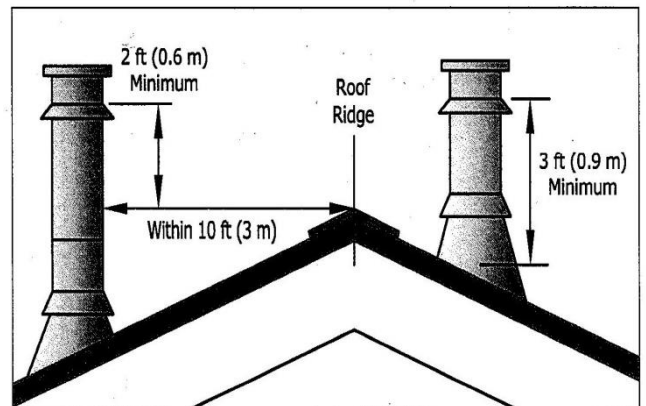

Chimney Draft Requirements: Chimney draft is the measurement of the pull or vacuum created by the chimney. It can be measured with a manometer and is expressed in inches of water (kPa). To measure you need to drill a small hole in the stovepipe between the flue collar and any stovepipe dampers installed into the stovepipe system. Insert the manometer connection into the hole and note the reading. Ideally you should have a reading of between -.03 and -.06 inches of water (kPa). If the chimney produces less than -.03 your fire can be very sluggish. In worst case instances combustion byproducts like smoke and carbon monoxide can be expelled from the stove. This can possibly create a very dangerous situation.

A draft of more than -.06 (kPa) will waste some of your heat by causing it to be drawn up the chimney too quickly. The higher the draft goes the more heat that is wasted up the chimney. A very strong overdraft can also cause the stove to over fire. Over firing can cause the stove to develop extremely high temperatures resulting in possible damage to the stove or a fire. Draft should never exceed -.08 (kPa). Over drafting can be controlled by installing a damper in the stovepipe. This damper can be a barometric or manual damper. It is recommended to have this damper installed during the stove installation. The damper may be installed in the vertical or horizontal portion of the stovepipe. The stovepipe damper must be installed and calibrated according to the damper manufacturer's instructions.

CAUTION: BE SURE TO FOLLOW ALL CODES AND SAFETY REQUIREMENTS WHEN INSTALLING THE STOVE.

CAUTION: THE USES OF ALUMINUM TYPE B GAS VENT FOR SOLID FUEL VENTING IS UNSAFE AND PROHIBITED BY THE NATIONAL FIRE PROTECTION ASSOCIATION CODE.

III. INSTALLATION OF STOVE

WARNING: THE INSTALLATION OF THESE STOVES MUST COMPLY WITH STATE AND LOCAL REQUIREMENTS AND BE INSPECTED BY THE STATE OR LOCAL INSPECTOR IF REQUIRED. NOTE: THESE STOVES ARE NOT APPROVED OR RECOMMENDED FOR USE IN MOBILE HOMES.

CAUTION: DO NOT CONNECT TO ANY AIR DISTRIBUTION DUCT OR SYSTEM

Connection of stove to the chimney should be made as directly as possible and not more than two bends when needed should be used. No reduction in flue pipe below 7 inches diameter heater outlet should be used. The pipe connecting the stove to the chimney should be at least 24 gauge. Slope the flue pipe back towards the heater 1/4 inch per foot of horizontal run, so that any condensation forming in the pipe will be carried back into the heater. The connector pipe should be installed so that the upper pipe section fits inside the lower section. This way the condensation, creosote or soot building up inside the pipe will stay inside the pipe as it flows down the inside surface. Horizontal pipe runs should have the pipe seams turned up. Chimney connectors must not pass through the ceiling, concealed spaces, or enter the chimney in the attic, REMEMBER, that all pipe sections must be connected with at least three sheet metal screws per joint. A manual or barometric damper is recommended to maintain a chimney draft between -.03 to -.06 inches of water (kPa). Draft should never exceed -.08 (kPa).

82 Clearance Diagram

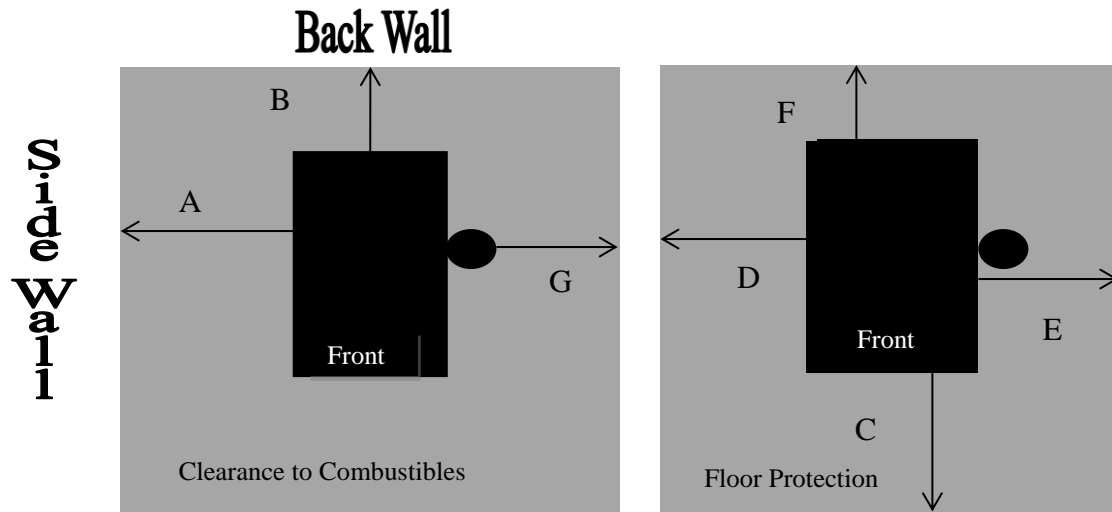

Minimum Clearances to Combustible Materials and Floor Protection

Minimum Clearances to Combustible Materials and Floor Protection		
A	Sides of Unit to Combustibles	36"
B	Back of Unit to Combustibles	36"
C	Floor Protection – Unit to Front	16"
D	Floor Protection – Unit to Side	8"
E	Floor Protection – Unit Flue Side to Side	12"
F	Floor Protection – Unit to Back	8"
G	Chimney Connector to Side Wall	18"

Floor protection must be listed to UL 1618 and provide insulation of at least 3/8" thick millboard having an insulation Factor of K - 0.84 (R - 0.45) and must extend a minimum of 8 inches on the non-flue side and back, 12 inches or 2" beyond the flue connector on the flue side of the ash door, and 16 inches in front of ash door. An easy means of determining if a proposed alternate floor protector meets requirements listed in this manual is to follow this procedure:

- 1) Convert specifications to R-value:
 - a. R-value given – no conversion needed.
 - b. k-factor given with required thickness (T) in inches: $R = 1/k \times T$
 - c. C-factor given: $R = 1/C$
- 2) Determine the R-value of the proposed alternate floor protector.
 - a. Use the formula in step (1) to convert values not expressed as "R"
 - b. For multiple layers, add R-values of each layer to determine the overall R-value.
- 3) If the overall R-value of the system is greater than the R-value of the specified floor protector, the alternate is acceptable.

Example:

The specified floor protector should be 3/8-inch thick material with a k-factor of 0.84. The proposed alternate is 4" brick with a C-factor of 1.25 over 1/8" mineral board with a k-factor of 0.29.

Step (a): Use formula to convert specification to R-value. $R = 1/k \times T = 1/.84 \times .375 = .446$

Step (b): Calculate R of proposed system

4" brick of C = 1.25, therefore $R_{brick} = 1/C = 1/1.25 = 0.80$

1/8" mineral board of $k = 0.29$, therefore $R_{\text{mineral board}} = 1/.29 \times 0.125 = 0.431$

Total $R = R_{\text{brick}} + R_{\text{mineral board}} = 0.8 + 0.431 = 1.231$

Step (c): Compare proposed system R of 1.231 to specified R of .446. Since the proposed system R is greater than required, the system is acceptable.

- a. Vent stove into a clean, lined, approved masonry chimney in good condition, conforming to local building codes and meeting the minimum standards of the National Fire Protection Association (NFPA).
- b. If connection is made through a combustible wall a listed and approved wall thimble/pass-through must be used following manufacturer's instructions. Alternative site built pass-through options are on following page.
- c. Stovepipe must be at least 18 inches from combustible ceiling and walls.
- d. Floor protection must be listed to UL 1618 and provide insulation of at least 3/8" thick millboard having an insulation Factor of $K - 0.84$ ($R - .45$) and must extend a minimum of 8 inches on the non-flue side and back, 12 inches or 2" beyond the flue connector on the flue side of the ash door, and 16 inches in front of ash door.
- e. Stove must be located at least 36 inches from combustible wall on all sides, unless otherwise specified on the plate on the stove.
- f. Stovepipe connection must have at least 3 screws per joint.

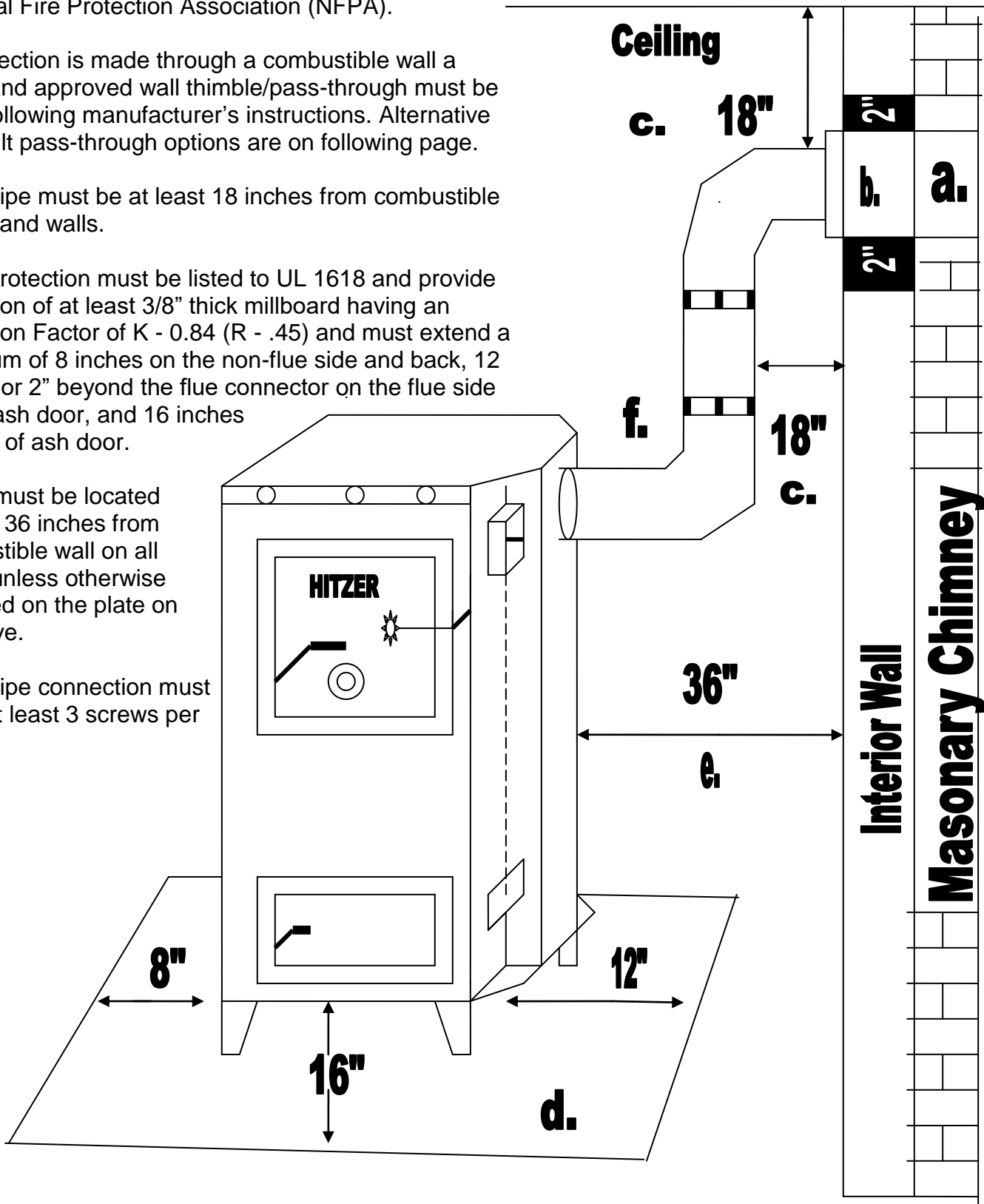

Installation

CHIMNEY INSTALLATION THROUGH WALL:

Here are four methods of combustible wall chimney connector pass-throughs. This information was provided from NFPA 211.

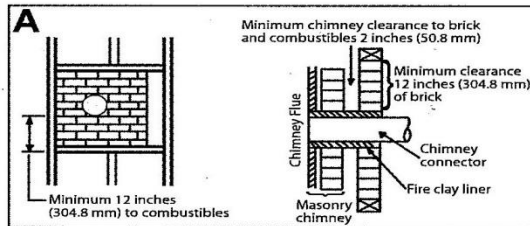

Method A. 12" (304.8 mm) Clearance to Combustible Wall Member: Using a minimum thickness 3.5" (89 mm) brick and a 5/8" (15.9 mm) minimum wall thickness clay liner, construct a wall pass-through. The clay liner must conform to ASTM C315 (Standard Specification for Clay Fire Linings) or its equivalent. Keep a minimum of 12" (305 mm) of brick masonry between the clay liner and wall combustibles. The clay liner shall run from the brick masonry outer surface to the inner surface of the chimney flue liner but not past the inner surface. Firmly grout or cement the clay liner in place to the chimney flue liner.

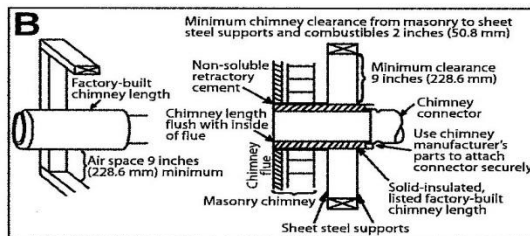

Method B. 9" (229 mm) Clearance to Combustible Wall Member: Using a 6" (152 mm) inside diameter, factory-built Solid-Pak chimney section with insulation of 1" (25.4 mm) or more, build a wall pass-through with a minimum 9" (229 mm) air space between the outer wall of the chimney length and wall combustibles. Use sheet metal supports fastened securely to wall surfaces on all sides, to maintain the 9" (229 mm) air space. When fastening supports to chimney length, do not penetrate the chimney liner (the inside wall of the Solid-Pak chimney). The inner end of the Solid-Pak chimney section shall be flush with the inside of the masonry chimney flue, and sealed with a non-water soluble refractory cement. Use this cement to also seal to the brick masonry penetration.

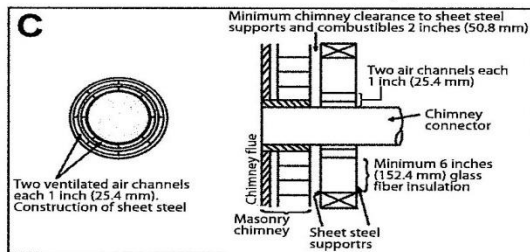

Method C. 6" (152.4 mm) Clearance to Combustible Wall Member: Starting with a minimum 24 gauge (.024" [0.6 mm]) 6" (152.4 mm) metal chimney connector, and a minimum 24 gauge ventilated wall thimble which has two air channels of 1" (25.4 mm) each, construct a wall pass-through. There shall be a minimum 6" (152.4 mm) separation area containing fiberglass insulation, from the outer surface of the wall thimble to wall combustibles. Support the wall thimble, and cover its opening with a 24 gauge minimum sheet metal support. Maintain the 6" (152.4 mm) space. There should also be a support sized to fit and hold the metal chimney connector. See that the supports are fastened securely to wall surfaces on all sides. Make sure fasteners used to secure the metal chimney connector do not penetrate chimney flue liner.

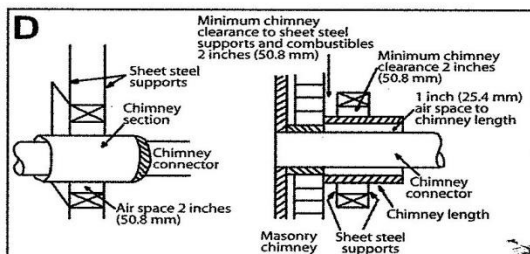

Method D. 2" (50.8 mm) Clearance to Combustible Wall Member: Start with a solid-pak listed factory built chimney section at least 12" (304 mm) long, with insulation of 1" (25.4 mm) or more, and an inside diameter of 8" (2" [51 mm] larger than the 6" [152.4 mm] chimney connector). Use this as a pass-through for a minimum 24 gauge single wall steel chimney connector. Keep solid-pak section concentric with and spaced 1" (25.4 mm) off the chimney connector by way of sheet metal support plates at both ends of chimney section. Cover opening with and support chimney section on both sides with 24 gauge minimum sheet metal supports. See that the supports are fastened securely to wall surfaces on all sides. Make sure fasteners used to secure chimney flue liner.

NOTES:

1. Connectors to a masonry chimney, excepting method B, shall extend in one continuous section through the wall pass-through system and the chimney wall, to but not past the inner flue liner face.
2. A chimney connector shall not pass through an attic or roof space, closet or similar concealed space, or a floor, or ceiling.

IV. OPERATION OF STOVE

WARNING: ALWAYS USE A CARBON MONOXIDE DETECTOR AND A SMOKE DETECTOR WHEN USING THIS APPLIANCE.

CAUTION: DO NOT USE CHEMICALS OR FLUIDS TO START THE FIRE. NEVER USE GASOLINE, KEROSENE, CHARCOAL LIGHTER FLUID, OR ANY TYPE OF FLAMMABLE FLUID TO START OR “FRESHEN UP” YOUR FIRE. KEEP ALL SUCH LIQUIDS WELL AWAY FORM THE HEATER WHILE IT IS IN USE.

CAUTION: DO NOT BURN GARBAGE OR FLAMMABLE FLUIDS.

CAUTION: THE FUELING DOOR AND ASH REMOVAL DOOR MUST REMAIN CLOSED DURING OPERATION.

Starting An Anthracite Coal Fire:

Starting an Anthracite coal fire takes time and patience. Take several sheets of newspaper, crumble into balls and place on top of grates. Next, lay fine kindling on top of the paper. The kindling must be dry and no larger than 3/4” in diameter. Layer the kindling in a crisscross fashion to allow good air flow. Open the draft control fully, this can be found on the back of the free standing units and the ash door slide. Then light the paper just inside the door. Now, close the loading door and allow the kindling to catch fire. After a few minutes, open the loading door an inch or two for a few seconds before opening completely. This method will allow smoke to clear away from the door opening before the loading door is completely opened. Add a good amount of small, compact pieces of hardwood when the kindling fire is burning hot. Keep the draft controls fully open to establish a hot fire quickly. Anthracite coal requires a hot sustained fire to ignite. When there is a well-established kindling wood fire going spread it out with a poker and start adding coal. Nut and/or pea are the preferred sizes. Add a thin layer, approximately the thickness of the coal, covering the entire grate area. If the entire grate area is not covered, the coal will not ignite. Keep the draft controls open. Once a layer has started to burn and turn red, another layer can be added.

Another method for starting an Anthracite coal fire is by using self-starting charcoal briquettes. **DO NOT USE LIGHTER FLUID OR ANY OTHER FLAMMABLE LIQUID!** First, start by making a substantial mound of briquettes in the center of the grates. Light the mound of briquettes. Allow the mound to burn until the charcoal has turned white. Once the charcoal fire has reached this stage it should be spread out over the entire grate area and start adding coal. Add a thin layer, approximately the thickness of the coal, covering the entire grate area. If the entire grate area is not covered, the coal will not ignite. Keep the draft controls open. Once a layer has started to burn and turn red, another layer can be added.

Continue adding layers of Anthracite coal until there is a solid bed of burning coal. Adding too much coal at one time can put the fire out. Allow sufficient time between each layer (at least 10-15 minutes), so that each layer has time to ignite thoroughly before the next layer is put in. When a substantial bed of burning coal has been established, fill the stove to approximately the top of the firebrick. Never load coal above the firebrick lining. A deep bed of coal will always burn more satisfactory than a shallow bed. Control the heat output of the stove by the amount of air (draft controls), not by the amount of fuel in the unit. When the deep bed of coal is completely ignited, the Dial Heat Regulator should be set to desired heat output.

Starting A Bituminous Coal Fire:

Bituminous coal is much easier to start because it is more volatile. Take several sheets of newspaper, crumble into balls and place on top of grates. Next, lay fine kindling on top of the paper. The kindling must be dry and no larger than 3/4" in diameter. Layer the kindling in a crisscross fashion to allow good air flow. Open the draft control fully, this can be found on the back of the free standing units and the ash door slide. Then light the paper just inside the door. Now, close the loading door and allow the kindling to catch fire. After a few minutes, open the loading door an inch or two for a few seconds before opening completely. This method will allow smoke to clear away from the door opening before the loading door is completely opened. Add a good amount of small, compact pieces of hardwood when the kindling fire is burning hot. Once this fire is established you can start to add coal. Size of Bituminous coal, sometimes referred to as lump coal, can vary greatly. It can range from so large it will almost not fit in the door to extremely small. All sizes will burn however bituminous coal has a low fusion temperature and the smaller sizes can fuse together. This can start to restrict air flow and the ability of the coal to burn. When this happens this block of burning coal must be broken up with a poker to restore proper operation. Add the coal in a couple of stages however it is not necessary to build it up in thin layers like anthracite coal. Do not ever build the coal bed higher than the firebricks as this can cause severe damage to your stove. When the coal bed is completely ignited, the Dial Heat Regulator should be set to desired heat output.

Adjusting Your Dial Heat Regulator:

The Dial Heat Regulator is the primary control for the combustion air for your fire. By controlling the combustion air to the fire you control the speed of the coal combustion process thus controlling the heat produced by the stove. What this control does is maintain the firebox at a given temperature by adding more or less air. There will be an initial trial and error period as you determine what stove temperature gives you the amount of heat you need in your house. Once this setting is determined you should not have to change the setting unless there is a major change outside. A good example of this is when we go from fall into the dead of winter and the house requires more heat. You may then need to turn the control up.. Likewise as the temperature starts to moderate towards spring you may have to turn it down. It is not however something you will be turning every day or much at all.

Here is the procedure to determine what your setting should be. First open the control and get your fire going as previously stated in these instructions. Once the fire is going, set the Dial Heat Regulator somewhere around mid-scale (Number 6-8). Leave it there for around 6-8 hours. If there is too much heat or not enough heat adjust the control up

or down one number. You then need to wait half a day or more again. It will take the stove several hours to stabilize at the new temperature. It will then take the house half a day or more to stabilize at the new temperature. If there is still too much or too little heat make another small adjustment and wait the same amount of time again. **IT IS VERY IMPORTANT TO MAKE SMALL ADJUSTMENTS AND PLENTY OF TIME IN BETWEEN ADJUSTMENTS OR YOU WILL ALWAYS BE CHASING THE PROPER SETTING AND NOT FIND IT.** Once you do find your setting you will not have to make many changes over the season as stated before. We do not advise turning the Dial Heat Regulator back more than one number at night and usually it is more satisfactory to allow the heater to operate with the setting in the same position day and night. It takes very little more fuel to maintain the temperature than to bring it back to normal in the morning.

WARNING: IF STOVE OR FLUE CONNECTOR PARTS GLOW RED YOU ARE OVER FIRING YOUR STOVE. DO NOT OVER FIRE. OVER FIRING CAN CAUSE A HOUSE FIRE AND CAN SERIOUSLY DAMAGE YOUR STOVE. IF THE STOVE IS OVER FIRING CLOSE AIR INTAKES AND DAMPERS TO SLOW DOWN THE BURN.

Adjusting Your Secondary Burn Chamber Damper:

The secondary burn chamber damper is the handle on the right side of the loading door that closes down across the door. This damper closes the flue exit hole at the top of the firebox forcing the smoke and combustion byproducts into the secondary burn chamber on the side of the stove. They enter the chamber where the two bricks lay at an angle. As they travel up the chamber more air is added to complete the combustion of the particles and gases that would normally pass up and out the chimney. This increases the efficiency of the stove. This damper should be closed once the fire is burning nicely.

Adjusting The Loading Door Spin Draft:

Air can also enter the fuel magazine through the spinner draft on the fuel door. This air is normally used to help eliminate puffing. Puffing usually happens in the spring or fall of the year or other times when not a lot of heat is needed. It is also during the first few hours after refueling. As new fuel is starting there is a lot of volatile gas being driven out of it. Normally these gases just burned off. However when the stove is turned down and not much heat is needed the thermostat controlling the draft closes. The gases now have no oxygen to burn and there is very little air movement through the stove causing the gases to build up. As the stove cools the thermostat reopens. Now there is oxygen and the gases ignite causing a puff. Opening the draft spinner keeps a small amount of air moving through the stove preventing this from happening. The draft spinner can be left open at other times also because there is not enough air entering to cause much difference in your heat output.

Shaking And Reloading:

When burning Anthracite coal, it will be necessary to shake the grates morning and evening. Shaking should consist of short fast strokes. Continue shaking until small live coals are falling into the ash pan the whole way along each grate. If you stop shaking with just a few red coals falling into the ash pan the ash will build up on the

grates causing the fire to be sluggish. The fire will not want to burn well, heat output will drop, and the fire will possibly go out. Do not permit ashes to remain piled high in the pan. **THERE MUST BE AN AIR SPACE OF A FEW INCHES BETWEEN THE ASHES IN THE ASH PAN AND THE GRATE BARS TO PREVENT DAMAGE, SUCH AS WARPING TO THE GRATE BARS THROUGH OVERHEATING. REMEMBER, WHEN BURNING COAL THE ASH PAN SHOULD BE EMPTIED DAILY. AFTER SHAKING MAKE SURE GRATES ARE SETTING FLAT WITH RIB DOWN. IF GRATES ARE LEFT UPSIDE DOWN WITH RIB FACING UP OR NOT FLAT SERIOUS DAMAGE MAY OCCUR. GRATES MAY WARP AND BECOME UNUSABLE.**

Reloading with Anthracite coal now depends on how deep of a bed of burning coal is left in the firebox. If there is a deep bed left you may be able to load the coal all at once. If there is a thin bed of coal left you will have to add the coal in layers allowing each layer to ignite before adding another. This is just as you did during start up.

When burning Bituminous coal, it will be necessary to shake the grates morning and evening also. Bituminous coal can have a tendency to fuse into clinkers. The amount of clinkering is dependent on the grade of coal you are burning and the temperature you are burning at. Before shaking you may have to break up ash clinkers with a poker. Shake now until bits of red burning coal are dropping into the ash pan. You can now reload with coal. If fire is very low you may have to add coal in two batches with some time for starting in between.

SOOT - FORMATION AND NEED FOR REMOVAL:

WHEN COAL IS BURNED, THE PRODUCTS OF COMBUSTION COMBINE WITH MOISTURE TO FORM A SOOT RESIDUE, WHICH ACCUMULATES ON THE FLUE LINING. WHEN IGNITED, THIS SOOT MAKES AN EXTREMELY HOT FIRE. THE CHIMNEY CONNECTOR AND CHIMNEY SHOULD BE INSPECTED AT LEAST TWICE MONTHLY DURING THE HEATING SEASON TO DETERMINE IF A SOOT BUILD-UP HAS OCCURRED. IF SOOT HAS ACCUMULATED, IT SHOULD BE REMOVED TO REDUCE THE RISK OF A CHIMNEY FIRE. ANY BUILDUPS MUST BE REMOVED.

CREOSOTE – FORMATION AND NEED FOR REMOVAL:

WHEN WOOD IS BURNED SLOWLY, IT PRODUCES TAR AND OTHER ORGANIC VAPORS, WHICH COMBINE WITH EXPELLED MOISTURE TO FORM CREOSOTE. THE CREOSOTE VAPORS CONDENSE IN THE RELATIVELY COOL CHIMNEY FLUE OF A SLOW-BURNING FIRE. AS A RESULT, CREOSOTE RESIDUE ACCUMULATES ON THE FLUE LINING. WHEN IGNITED THIS CREOSOTE MAKES AN EXTREMELY HOT FIRE. WHEN BURNING WOOD, THE CHIMNEY CONNECTOR AND CHIMNEY SHOULD BE INSPECTED AT LEAST ONCE EVERY TWO MONTHS

DURING THE HEATING SEASON TO DETERMINE IF A CREOSOTE BUILDUP HAS OCCURRED. ANY BUILDUPS MUST BE REMOVED**DISPOSAL OF ASHES:**

Ashes should be placed in a metal container with a tight fitting lid. The closed container of ashes should be placed on a noncombustible floor or on the ground, well away from all combustible materials, pending final disposal. If the ashes are disposed of by burial in soil or otherwise locally dispersed, they should be retained in the closed container until all cinders have thoroughly cooled.

CAUTION: THE ASH PAN AND PARTS OF YOUR STOVE WILL BE HOT. ALWAYS WEAR GLOVES AND PROTECTIVE CLOTHING WHEN EMPTYING ASH PAN OR WORKING ON A HOT OR BURNING STOVE.

COAL STORAGE: Storing your coal is quite simple. Coal is not affected by insects, rodents, or moisture. Bagged coal can be stacked anywhere that is convenient. Bulk coal you will want to have a bin of some sort just so it doesn't spread all over. Either bulk or bagged it can be stored inside or outside because it is unaffected by moisture. However if stored outside you may want to cover it or you will have to dig it out of the snow. Even some snow in with the coal is not a problem. Where a problem could develop is if a very large amount of snow is mixed in with the coal. That amount of moisture could put out the fire especially if the fire is low.

V. MAINTAINING YOUR HEATING SYSTEM

NOTE: FAILURE TO MAINTAIN OR PROPERLY USE THIS APPLIANCE MAY CAUSE INJURY OR A HOUSE FIRE. IT WILL ALSO SHORTEN THE LIFE OF YOUR STOVE. AT THE BEGINNING OF EACH HEATING SEASON THIS APPLIANCE, THE CONNECTOR PIPE, AND CHIMNEY SHOULD BE INSPECTED TO SEE THAT IT IS CLEAR AND IN GOOD WORKING CONDITION.

End of season maintenance:

Moisture is your enemy. Summertime moisture and high humidity can be absorbed by dust and fly ash and cause rust and corrosion. A complete cleaning of the stove and venting system will help reduce this. Brush down all fly ash from the interior of the stove. Then you should vacuum out the fly ash from inside the stove including ledges and corners. Check outside painted surface of stove. If surface rust or blemishes are present lightly rub with fine steel wool to remove. You can then touch up the paint with high temperature stove paint available at your Hitzer dealer.

Next clean the venting system. Disconnect the chimney connector pipe and clean all fly ash from it especially elbows and horizontal runs. It is not necessary to reinstall this pipe till you are ready to use the stove again in the fall. Have the chimney inspected and cleaned if necessary.

At the beginning of each heating season this appliance, the connector pipe, and chimney should be inspected to see that they are clear and in good working condition.

For more information in the proper installation and operation of your quality HITZER heater contact your local HITZER dealer.

LIMITED WARRANTY AGREEMENT

Hitzer, Inc., an Indiana Corporation, currently maintaining its office at 269 E Main Street, Berne, Adams County, Indiana, does herein make the following Limited Warranty as herein after set forth.

1. Hitzer, Inc. currently manufactures a stove designated as a Hitzer stove. In the manufacture of said stove, Hitzer Inc. utilizes components that Hitzer Inc. does not manufacture and/or produce and said limited warranty specifically excludes any and all components of said stove that are not manufactured by Hitzer Inc.
2. Said limited warranty shall be limited only to the original purchaser of a Hitzer stove, either from the aforementioned offices of Hitzer Inc. or from a duly authorized dealer and/or representative of Hitzer Inc.
3. This limited warranty shall commence as of the date wherein said purchase is made by the aforementioned original purchaser. Said limited warranty shall continue for a period of (5) years from and after that date, provided that the requirements hereinafter set forth are complied with in all detail by the original purchaser.

Said limited warranty shall apply only to those components of said stove that are specifically manufactured by Hitzer, Inc. Should an original purchaser during said period of time allege that a defect has occurred with reference to a part and/or component of said stove manufactured by Hitzer, Inc., said original purchaser shall send said defective part to the aforementioned offices of Hitzer Inc. for determination therewith to be made by Hitzer Inc.

Hitzer, Inc., should it determine that said component was defective, shall thereafter replace said component at no cost to the original purchaser. All shipping charges shall be the responsibility of the original purchaser and the said Hitzer, Inc. shall have the final determination and be the final

determiner as to whether or not said component is defective. Any labor costs attendant therewith shall be borne solely by the original purchaser.

4. EXCLUSIONS

Since Hitzer, Inc. does not manufacture the following: paint, glass, gasketing, fire brick, brass trim, fans, grates, cast doors, and in addition thereto, any other component not specifically mentioned, which is not manufactured by Hitzer, Inc, any defect as to any of the aforementioned shall not be covered in said warranty and is herein specifically excluded there from.

Likewise any damage produced to the components manufactured by Hitzer, Inc. from misuse, over burn, improper installation, including failure to comply with local building codes or any other abuse that Hitzer, Inc. should determine has occurred in the utilization of said stove, is herein specifically disclaimed.

5. This limited warranty is the only warranty supplied by Hitzer Inc. All other warranties, whether expressed or implied are hereby expressly disclaimed and original purchaser's recourse is expressly limited to the warranties set forth herein.

ALL LIABILITY FOR ANY CONSEQUENTIAL DAMAGES IS
DISCLAIMED AND EXCLUDED HERE FROM. SOME STATES
DO NOT ALLOW EXCLUSION OR LIMITATION OF INCIDENTAL
OR CONSEQUENTIAL DAMAGES, SO THE ABOVE LIMITATION
OR EXCLUSION MAY NOT APPLY TO YOU

6. To make claim under this limited warranty, contact the dealer from whom you purchased this unit. If you dealer cannot be reached or is unable to provide service, contact Hitzer Inc.

In the event the unit must be returned to the factory for inspection or repair, the original purchaser must pay shipping to and from

Hitzer, Inc.
269 E Main St.
Berne, In 46711
260-589-8536

Hitzer Inc.
269 E Main St.
Berne, In 46711

In order for the above stated limited warranty to be effective and binding upon Hitzer, Inc., this portion herein must be detached and sent by the original owner to Hitzer, Inc. to the above stated address within ten (10) days from the date of purchase of said stove.

Owner's Name: _____

Address: _____

Telephone No. _____

Date Purchased: _____

Model No: _____

Serial No: _____

Dealer's Name and Address:

